

Material: Resin

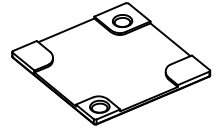

2:1

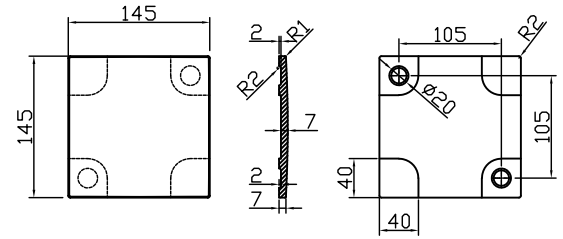
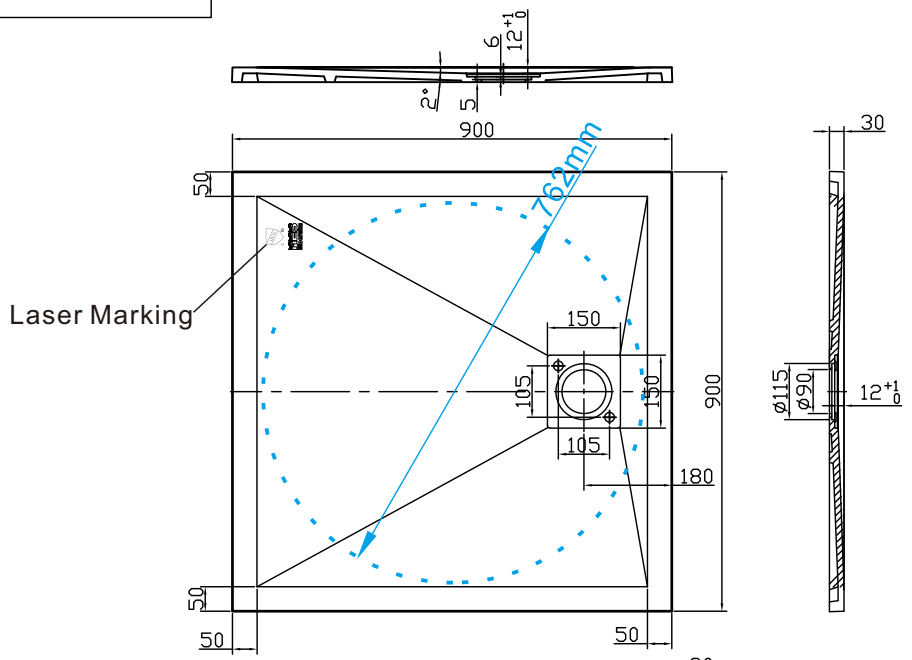
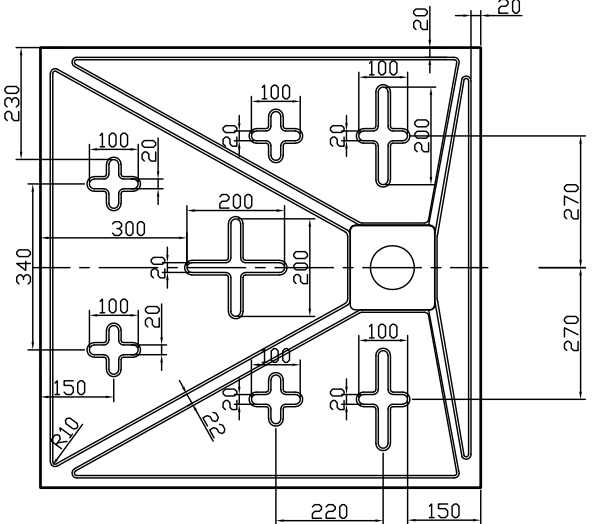
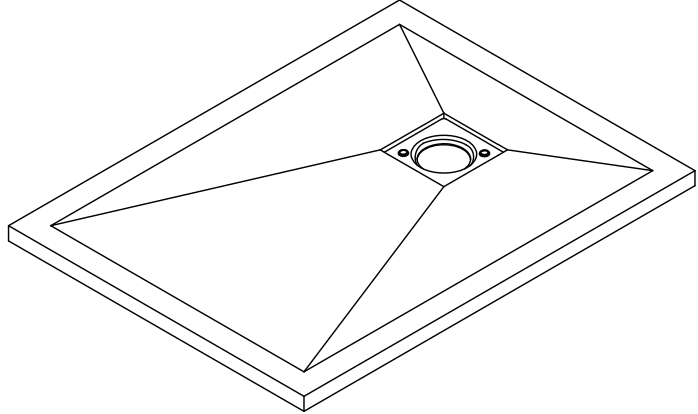

- Technical requirements:
1. No bubble, shrinkage and other defects;
 2. No tolerance IT12;
 3. Rounded R2-3 is not marked.
 4. Black surface bump effect treatment, see the list requirements.
 5. No parallel wall thickness 12mm.

Material: Resin

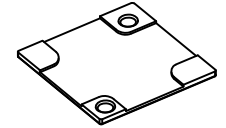
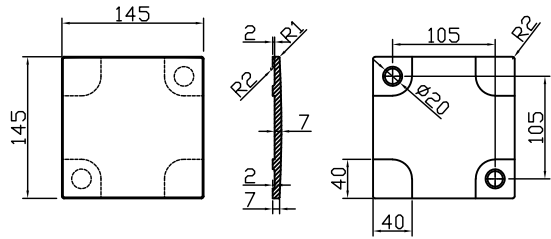
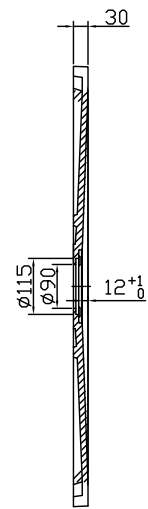
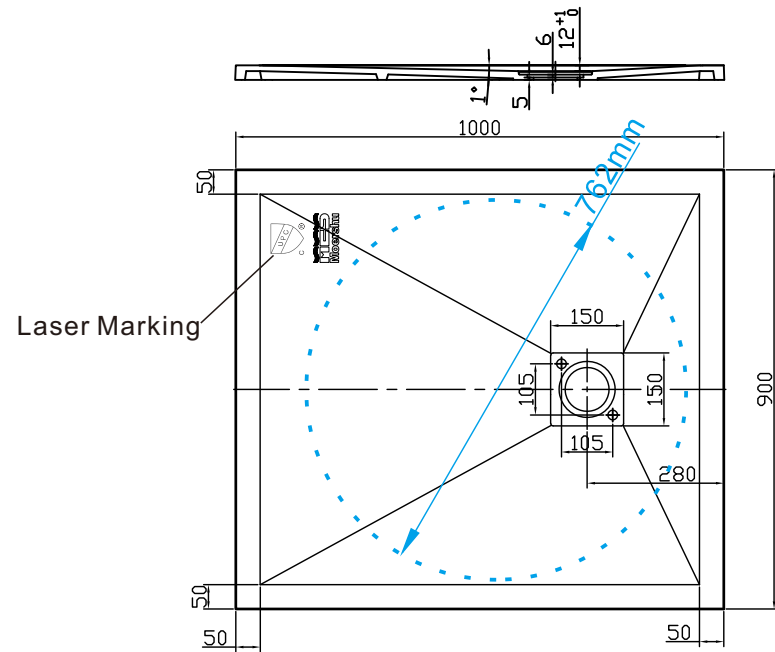

2:1

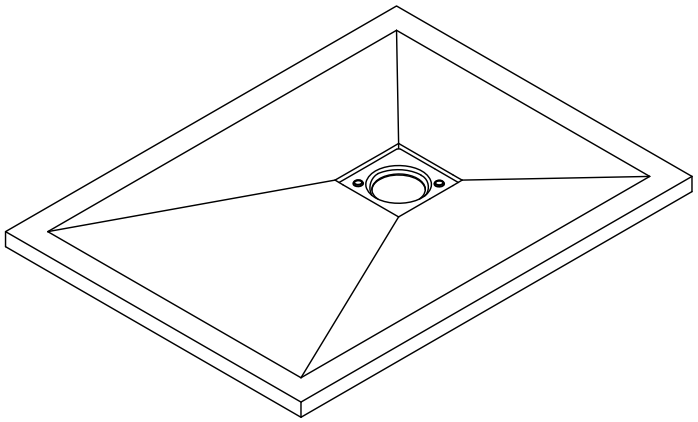
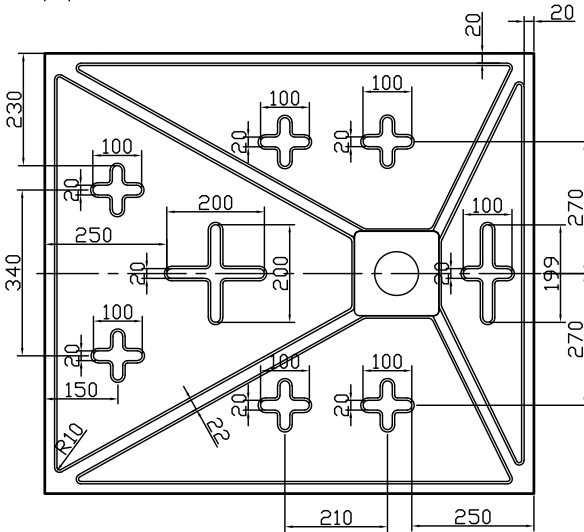

- Technical requirements:
1. No bubble, shrinkage and other defects;
 2. No tolerance IT12;
 3. Rounded R2-3 is not marked.
 4. Black surface bump effect treatment, see the list requirements.
 5. No parallel wall thickness 12mm.

shower trays			
Phase marker	quantity	scale	
	1		100*90

Material:Resin

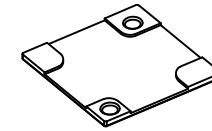
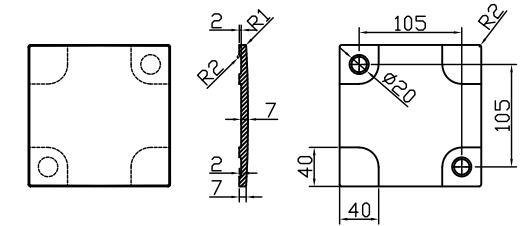
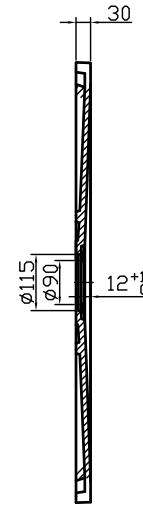
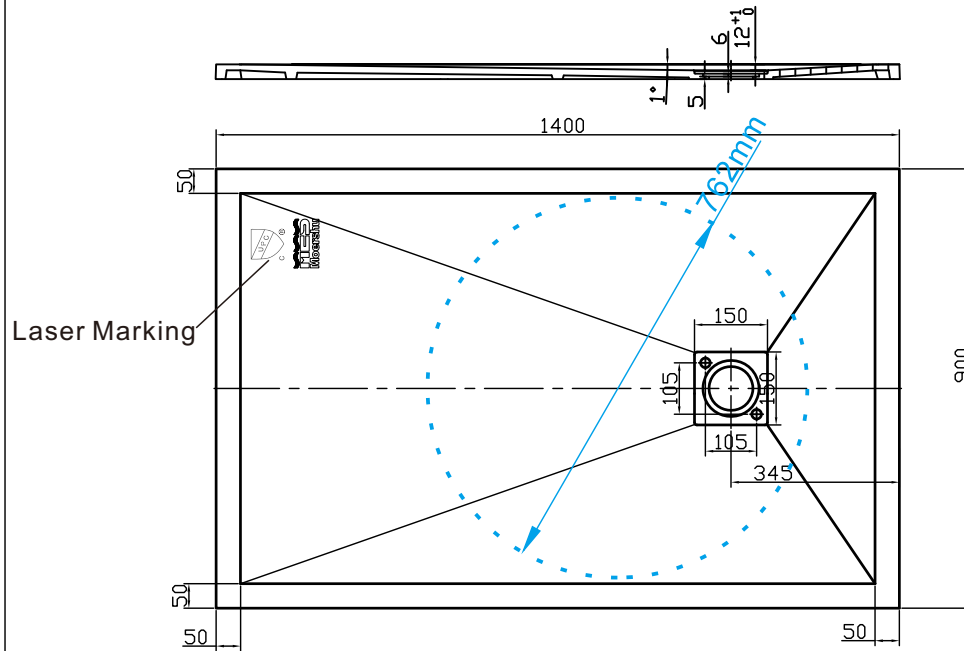

2:1

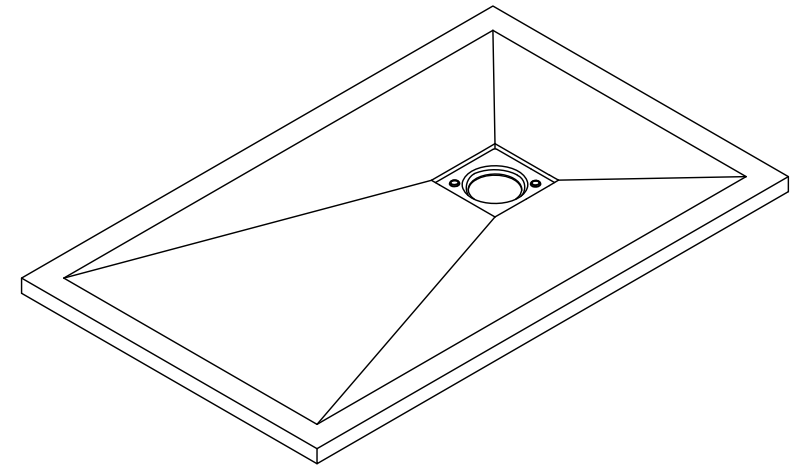
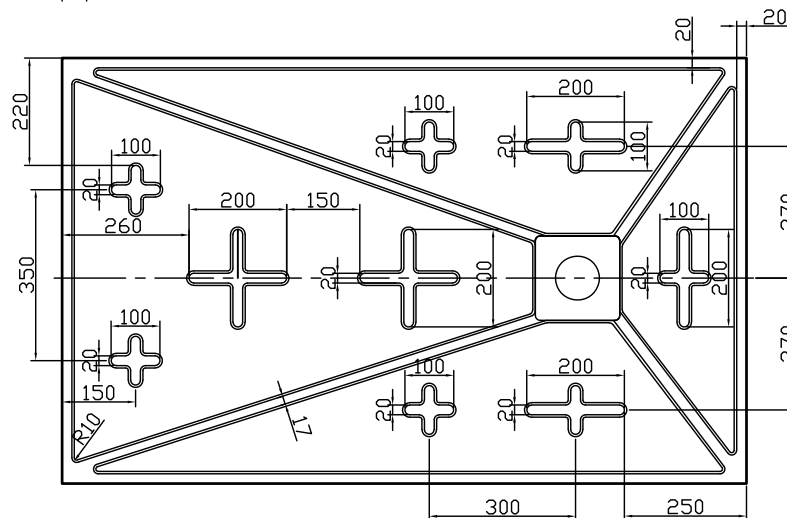

Technical requirements:

1. No bubble, shrinkage and other defects;
2. No tolerance IT12;
3. Rounded R2-3 is not marked.
4. Black surface bump effect treatment, see the list requirements.
5. No parallel wall thickness 12mm.

shower trays			
Phase marker	quantity	scale	
	1		140*90

